

Company Name: \_\_\_\_\_

Address: \_\_\_\_\_

City: \_\_\_\_\_ State: \_\_\_\_\_ Zip: \_\_\_\_\_

Contact: \_\_\_\_\_

Phone: \_\_\_\_\_ Fax: \_\_\_\_\_

E-mail: \_\_\_\_\_



ISO 9001:2008 REGISTERED WITH DESIGN

PHONE: 855.800.9568 - FAX: 716-667-6837

EMAIL: [webinfo@eltlift.com](mailto:webinfo@eltlift.com)

WEB: [www.eltlift.com](http://www.eltlift.com)

## CUSTOM PLATE STYLE C-HOOK ORDER FORM

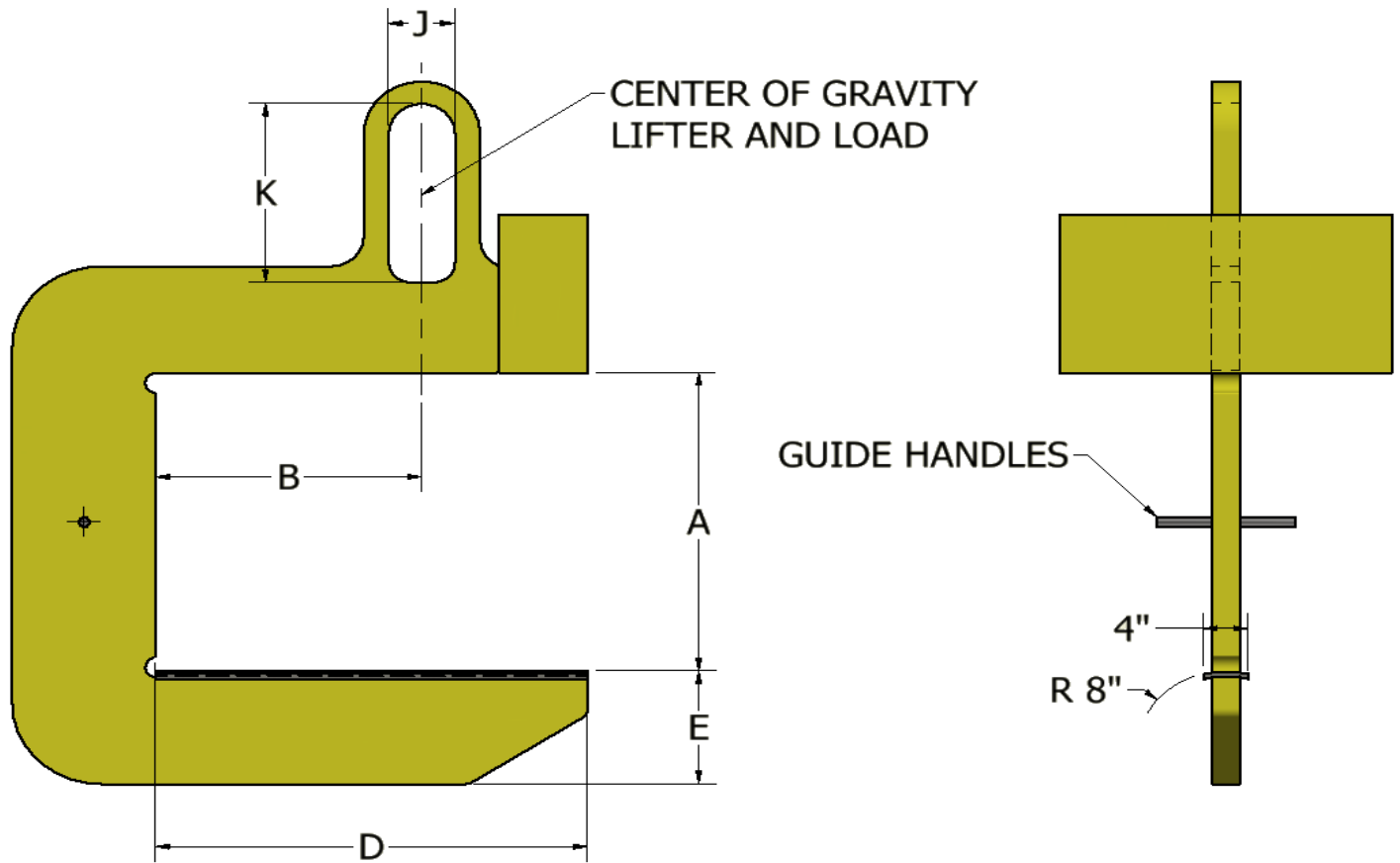

### SPECIFICATIONS

Additional Information (Notes/Dimensions):

LB. CAPACITY	
A:	IN. (VERT CLEARANCE)
B:	IN. (1/2 MAX COIL WIDTH)
D:	IN. (LIFT ARM LENGTH)
E:	IN. (LIFT ARM DEPTH))
J:	IN. (BAIL WIDTH)
K:	IN. (BAIL HEIGHT)

- NOTES:**
1. Lifter arm length allows sufficient width of larger coils to be handled without protrusion of lift arm past edge of coil.
  2. All loads must be centered under lifting bail.
  3. Please verify lifting bail will suit crane hook.

PLEASE NOTE: WEIGHT AND DIMENSIONS CAN VARY AND ARE APPROXIMATE AND FOR REFERENCE ONLY. SPECIFIC WEIGHT CAN NOT BE DETERMINED UNTIL THE UNIT IS FABRICATED.